

Smart Flow Transmitter

Versatile, Powerful Sensing Device

Description

The Smart Flow Transmitter (SFT) extends the versatility and power of the microprocessor to field flow sensing devices. The SFT processes inputs from flow, temperature and pressure sensors and calculates compensated flow data for precision volumetric or mass flow measurements of both liquids and gases.

The SFT accepts low level sine wave, DC pulse and modulated carrier input signals. Pressure and temperature inputs can be either analog current or voltage. Data from the individual sensors can be transmitted, either scaled or unscaled, to a control room for individual sensor observation.

Density and viscosity corrections are performed by the SFT software using Universal Viscosity Curves and Reynolds Number calculations for liquid and gas. Cubic spline or linear interpolation can be selected for optimum flow output linearization.

Two-way communications between the SFT and a hand-held terminal or personal computer are achieved via an RS232 port. An operator can monitor process variable information to verify sensor operation, change scale factors and make on-line program alterations. The comprehensive SFT software includes self-diagnostics, which are performed every 60 seconds, and all stored program data are saved in a non-volatile memory.

When using the SFT with turbine flowmeters, the output of the turbine is linearized over the repeatable range of the flowmeter. When used for mass measurement, the combination of a turbine flowmeter and the SFT offers distinct advantages over a coriolis meter. These include better accuracy, shorter response time, lower pressure drop and lower cost. The quick response time offers particular benefits in process mixing and blending by avoiding errors due to long settling times, which are inherent in other methods of measurement.



Smart Flow Transmitter

Versatile, Powerful Sensing Device

Features

- Provides user-selectable K-factor outputs for ease of replacement
- Linearizes output to $\pm 0.1\%$ of reading over maximum repeatable range of flowmeter
- Conditions modulated carrier or magnetic pickoffs
- Field programmable and configurable
- Accepts low level sine wave, DC pulse and modulated carrier flowmeter inputs
- Corrects for density and viscosity using UVC and Reynolds Number calculations for liquid and gas
- Monitors all process variables, flow rate, pressure and temperature
- Supports a wide variety of flowmeters
- Mass or volumetric flow output
- NEMA 4X enclosure (explosion-proof optional)

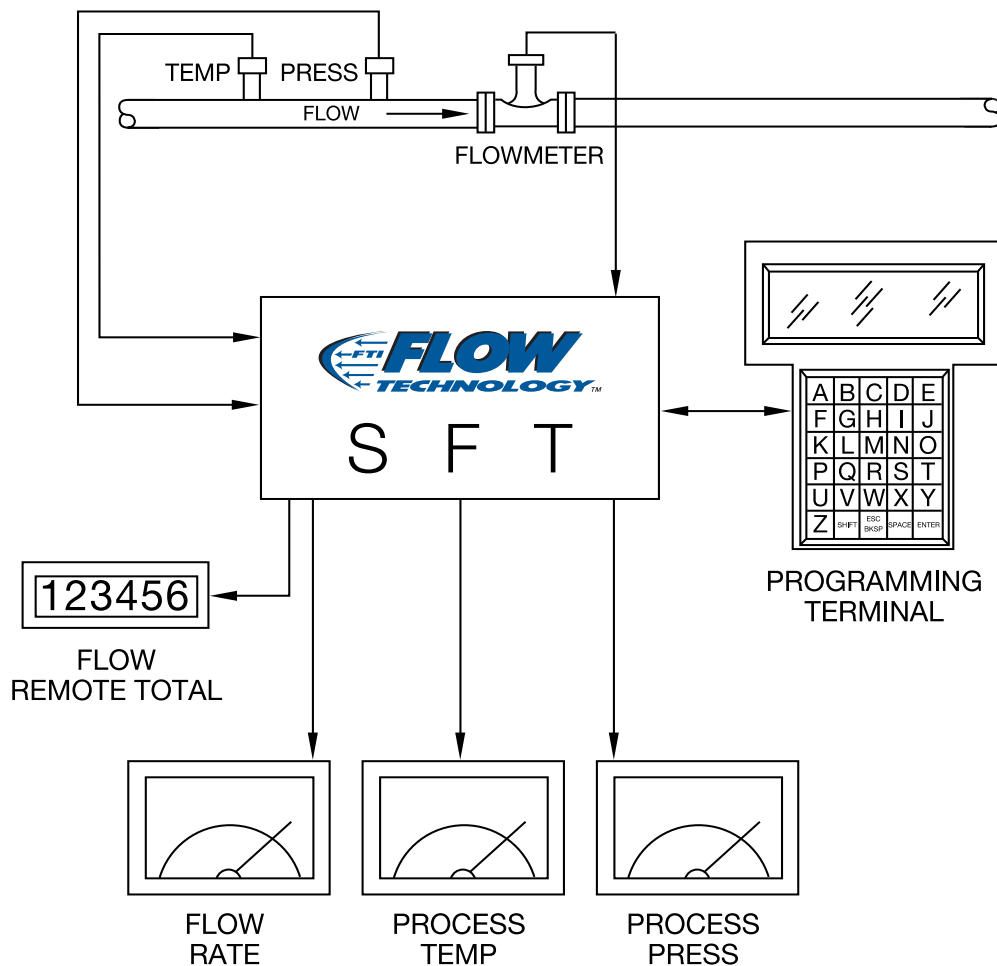

Typical System Diagram

Examples of Operation Sequence When Used with Turbine Flowmeters

Liquids

- 1) Determine temperature from input
- 2) Retrieve actual kinematic viscosity from kinematic viscosity versus temperature table
- 3) Measure input flowmeter frequency
- 4) Calculate input frequency \div kinematic viscosity (Hz/v)
- 5) Determine K-factor versus Hz/v from user table by user-selected linear interpolation or cubic spline
- 6) Calculate flow rate (input frequency \div actual K-factor)

Additional Calculations:

- 7) Determine liquid density from density versus actual temperature table
- 8) Calculate mass flow rate (volumetric flow rate \times actual density)

Gases

- 1) Determine temperature from input
- 2) Determine pressure from input
- 3) Retrieve actual absolute viscosity from absolute viscosity versus temperature table
- 4) Calculate density using actual temperature and pressure by ideal gas law
- 5) Calculate kinematic viscosity (absolute viscosity \div actual density)
- 6) Measure input flowmeter frequency
- 7) Calculate input frequency \div kinematic viscosity (Reynolds Number equivalent, Hz/v)
- 8) Determine K-factor versus Hz/v from user table by user-selected linear interpolation or cubic spline
- 9) Calculate flow rate (input frequency \div actual K-factor)

Additional Calculations:

- 10) Calculate mass flow rate (volumetric flow rate \times actual density)

Enclosure Options

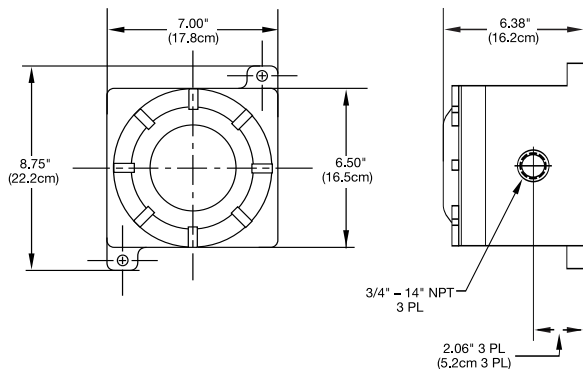

Group B Explosion-Proof

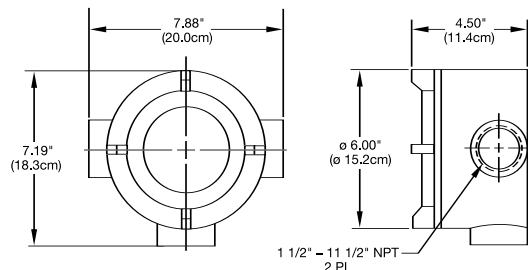

Group C&D Explosion-Proof

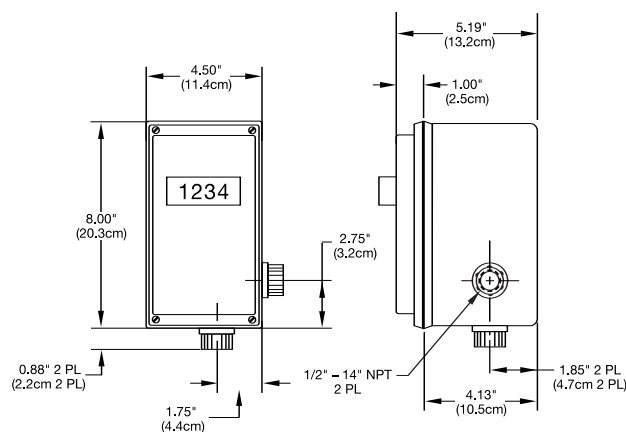

NEMA 4X Shown with Universal Display

Drawings not to scale.

Model Numbering System



Basic Model & Revision No.

Input Power

- 1 = 120 VAC
- 2 = 220/240 VAC
- 3 = 24 VDC
- 4 = 100 VAC
- 5 = 208 VAC

Flow Input

- A = Mag
- B = Pulse
- C = RF
- D = Other RF (330 mH)

Temperature Input

- G = 4–20 mA
- H = 0–5 VDC
- I = 1–5 VDC
- 0 = 0–10 VDC

Pressure Input

- G = 4–20 mA
- H = 0–5 VDC
- I = 1–5 VDC
- 0 = 0–10 VDC

Enclosure

- 1 = No Enclosure
- 6 = NEMA 4X
- 7 = NEMA 4X with MS Connectors
- 8 = Group D
- 9 = Group B
- A = NEMA 4X, MS Connectors with Universal Display
- C = NEMA 4X with Universal Display

Isolation

- N = Non-Isolated

Pressure Output

- G = 4–20 mA

Temperature Output

- G = 4–20 mA

Flow Output (Analog)

- G = 4–20 mA
- H = 0–5 VDC
- I = 1–5 VDC
- 0 = 0–10 VDC

Flow Output (Pulse)

- H = 0–5 VDC
- 0 = 0–15 VDC

Specifications

Standard Inputs

Flow	One input, user-selectable
<i>Frequency:</i>	0–5 kHz
Pulse	0–3.5 VDC (minimum), 35 VDC (maximum)
RF	10 Hz–5 kHz
Mag	Sensitivity 10 mV p-p 1 Hz–5 kHz
Pressure	One analog input, user-selectable 4–20 mA, 1–5 VDC, 0–5 VDC, or 0–10 VDC
Temperature	One analog input, user-selectable 4–20 mA, 1–5 VDC, 0–5 VDC, or 0–10 VDC

Optional Inputs/Outputs

Bi-directional flow, frequency input
(external supporting circuitry required)

Standard Outputs

Flow	
<i>Frequency:</i>	Linearized, pulse train, scalable 0–5 kHz TTL compatible 0–5 VDC or 0–15 VDC
<i>Analog:</i>	Pass through raw frequency Linearized, scaled (user-selectable) 4–20 mA, 1–5 VDC, 0–5 VDC, or 0–10 VDC
Pressure	4–20 mA analog, user-scalable
Temperature	4–20 mA analog, user-scalable
Units of Measure	Engineering units are user-defined
Compensation	Compensates by correcting for changes in fluid density and viscosity using UVC and Reynolds Number techniques.

Programming

Port	RS232 ASCII communication
Communications Hardware	Program from dumb terminal, hand-held terminal, personal computer or laptop computer

Linearization

Flow	20-point, user-selectable, cubic spline or linear interpolation
------	---

Performance

Linearization <i>Frequency:</i>	±0.1% of reading or better over flowmeter's repeatable range
<i>Analog:</i>	±0.2% of reading or better
Step Response <i>Frequency:</i>	50 milliseconds typical
<i>Analog:</i>	100 milliseconds typical
Temperature Stability	100 PPM per °C

Physical Environment

Standard Power	20–35 VDC at 250 mA (unregulated) (150 mA for 4–20 mA drive)
Optional Power	100 VAC, 120 VAC, 208 VAC, 220/240 VAC ±10%, 50/60 Hz
Temperature Range <i>Operating:</i>	-40° F to +185° F (-40° C to +85° C)
<i>Storage:</i>	-58° F to 212° F (-50° C to +100° C)
Housing	NEMA 4X with MS connectors NEMA 4X with conduit hubs Explosion-proof
Optional	Universal Display mounted integral (see Universal Display data bulletin for specifications)

Accessories

	Part No.
Hand-held terminal	06-91978-01
Terminal cable assembly for hand-held terminal	19-91979-01
Serial cable for SFT to personal computer (9–25 pin)	19-91980-XY*

Accessories

	Part No.
Serial cable for SFT to personal computer (9–9 pin)	19-91981-XY*
Software–Terminal emulator converter for personal computer	01-88295-101

*XY = Length in Feet

Specifications are for reference only and are subject to change without notice.

Local Representative:



8930 S. Beck Avenue, Ste 107, Tempe, Arizona 85284 USA
Tel: (480) 240-3400 • Fax: (480) 240-3401 • Toll Free: 1-800-528-4225
E-mail: ftimarket@ftimeters.com • Web: www.ftimeters.com

DB 62061 Rev E © 2001 FTI Flow Technology, Inc. Printed in USA