

# FT Series

## Turbine Flowmeters for Gas Applications (Metric)

### Description

Flow Technology's FT Series turbine flowmeters utilize a proven flow measurement technology to provide exceptionally reliable digital outputs. Because of their versatility, these flowmeters are the solution for a variety of process and test gas flow sensing applications. FT Series turbine flowmeters, which range in size from 1/2 inch to 4 inches, offer a high turn-down capability, repeatability of  $\pm 0.1\%$  of reading, and a typical linearity of less than 0.1% when mated to linearizing electronics.

The precision, axial-mounted rotor design of the standard turbine flowmeter allows it to operate effectively in flow rates from 11.3 to 42,480 ALPM, with the linearity rated at  $\pm 1.0\%$  of full scale over the normal 10:1 turn-down range. All turbine flowmeters can typically achieve  $\pm 0.1\%$  linearity over the full operating range with linearizing electronics and a 20 point calibration. Typical operating pressures for the standard meters are 349 BarG with custom configurations capable of 2,068 BarG.

A choice of construction materials can be specified for the turbine flowmeter's housing, rotor and bearings, with the standard being stainless steel and ball bearings.

### Features

- High turn-down capability.
- Excellent repeatability, less than  $\pm 0.1\%$  typical
- Linearity  $< 0.10\%$  with linearizing electronics, typical with 20 pt calibration.
- Extensive primary standard NIST traceable calibration capability, offering a wide range of flow rates and pressure. Accuracy less than  $\pm 0.30\%$  to  $\pm 0.50\%$ , dependent on calibrator.
- Standard materials of construction are 316 SS housing and 430F SS rotor.
- Robust, compact design capable of compliance to severe shock and vibration requirements.
- Standard pressure capabilities up to 349 BarG.
- Custom designs to meet the specific application are routine, not the exception.



FT Series Meters

### Specifications

Calibration accuracy	$\pm 0.30\%$ of reading, traceable to NIST
Repeatability	$\pm 0.10\%$ of reading, typical
Linearity	$\pm 0.10\%$ with linearizing electronics typical with 20 pt calibration
Housing material	316 stainless steel, standard
Rotor material	430F stainless steel, standard
Temperature range	-268 to 149°C
Operating pressure	Up to 2,068 BarG, dependent on fitting
Ball bearing material	440C stainless steel or equivalent
Pick-off's	Modulated carrier and magnetic
Straight Run	10D upstream and 5D downstream minimum
Recommended filtration	Ball bearings: 10 to 100 microns (less filtration with larger sizes)



## Turbine Flow Meter Model Number Selection and Sizing Guidelines

There are 4 major steps in defining a turbine flow meter; these are:

- Choosing the flow meter size
- Bearing selection
- Pick-off selection
- Calibration requirements

These components are interrelated and should be considered as a system to obtain optimum meter performance. Additional options need to be selected that are related more to personal preference. These are end fitting type, materials of construction, and units of measure.

### Step 1: Meter size and flow range selection

Detailed below are the considerations that should be taken into account when sizing a flow meter.

- Due to the laws of physics, for optimum results any flow meter (including turbine flow meters) should be operated as high up in their turndown range as possible.
- Clearly, there is a trade off between your allowable pressure drop and the size of meter that you can install into your process. In other words, at a given flow rate, a smaller meter will operate higher up in its flow rate range, but will generate a higher pressure drop.
- When selecting the size and flow range of the meter the pick-off selection must be considered. RF pick-offs place no drag on the rotor while a magnetic pick-off sensor creates a small amount of drag on the rotor as each blade passes through the magnetic field.
- Ideally, it is beneficial to stay within a 10:1 turndown range. However, the phenomenal repeatability and primary calibration accuracy's enable the Flow Technology turbine to provide outstanding performance over a 50:1 turndown.
- See page 4 for available flow ranges.

### Step 2: Pick-off Selection

#### Reasons to choose a RF pick-off

- Use on FT-24 and smaller meters.
- Use when real time temperature and pressure correction (UVC calibration) is required.
- Flow meter does not require recalibration when pick-off is changed.
- Must be used in conjunction with an amplifier to produce a square wave frequency output.
- Can not be used above an FT-40 size flow meter.

#### Reasons to choose a Magnetic pick-off

- Use on FT-32 and larger meters.
- Use when a direct millivolt output is required.
- Flow meter should be recalibrated when pick-off is changed.
- Can be used on smaller flow meters with reduced flow range.

#### Pick-off Options

- Standard pick-offs have upper operating temperature of 177°C.
- Most electronics are available in hazardous area rated enclosures. If system certification is required, pick-offs are available with various ratings.
- Amplified pick-offs are available that house circuitry in the pick-off body to provide a high level 0 – 5 volt square wave pulse output. DC power is required.
- See page 6 for pick-off selection options.

#### Pick-off Mounting Configuration

#### MS connector

- Pick-offs have two or three pin MS connectors.
- Connection to the pick-off is via a mating MS connector with soldered connections and loose wire.
- Typical installation is on test stands or on board applications.
- A junction box or conduit **can not** be attached to this pick-off style.
- This pick-off is used on flow meters that **do not** have 1" MNPT nipples welded to the meter body surrounding the pick-off. Flow meters with threaded end connections typically do not have the 1" nipple.

#### Flying leads with threaded connection

- Pick-offs have flying leads extending from the potted pick-off body.
- Mechanical connection to the pick-off is via a ½" MNPT thread integral to the top of the pick-off body or the 1" MNPT thread of the flow meter nipple.
- This pick-off style is required when a junction box and rigid or flexible conduit is to be mounted directly to the pick-off body.
- Typical installation is a more industrial environment.
- This threaded body pick-off is used on flow meters that **do not** have 1" MNPT nipples welded to the meter body surrounding the pick-off. A flying lead pick-off with smooth body are used on flow meters that **do** have the 1" MNPT nipple. Flow meters with threaded end connections typically do not have the 1" nipple. Flow meters with flanged end connections typically do have the 1" nipple.

## Step 3: Bearing Selection

- Bearings are available in two styles. Standard ball with 440C stainless races, balls, and cage or 440C stainless races, balls, and a phenolic resin cage.
- See page 5 for bearing selection options.

### Ball bearings (model # code "A")

- Standard bearing option.
- Materials of construction are 440C SS or equivalent races, balls and loose crimp stainless cage.
- Bearing has open race and requires clean, dry operating fluid.
- Low frictional drag provides the widest possible flow range.
- Ball bearing set can be replaced in the field.
- 10 to 50 micron filtration required, dependent on meter size.
- Operating temperature range of -268° to 149° C.

### Ball bearings (model # code "H")

- Materials of construction are 440C SS race and balls with a phenolic resin cage.
- Bearing has open race and requires clean, dry operating fluids
- The phenolic cage provides a degree of lubricating property to the bearing, increasing durability and life.
- Slightly more bearing drag is created by the phenolic cage vs. the loose crimp cage of the standard ball bearing.
- Ball bearing set can be replaced in the field.
- 10 to 50 micron filtration required, dependent on meter size.
- Operating temperature range of -268° to 149° C.

## Step 4: Calibration Selection

- Flow Technology has one of the world's largest liquid and gas primary calibration facilities.
- The ability to accurately calibrate a flow meter with trace ability to international standards is one of the fundamental requirements in any flow metering application.
- Flow Technology offers a range of gas calibration technologies and sizes, including Bell Provers, Piston Provers and flow transfer stands.
- A 10 data point calibration is offered as standard, 20 and 30 point calibrations are offered as options. A higher number of data points will define the calibration curve in more detail. If linearizing electronics will be used a minimum of a 20 point calibration is recommended.
- Pressure and temperature variation, thus density and viscosity changes do shift the flow meter calibration curve.
- Calibration in air at standard conditions is the most economical option, FTI does offer the capability to calibrate the meters in a pressurized environment to simulate actual operating conditions.

### Actual vs. Standard units of measure

- Turbine flow meters measure the actual volume of gas passing through the meter at the operating temperature and pressure, They are therefore sized in Actual Liters per Minute (ALPM).
- Standard Liters per Minute (SLPM) is the equivalent volume of gas referenced back to standard temperature and pressure.
- The perfect gas law used to convert between ALPM and SLPM is:  

$$ALPM = SLPM(1.013 \text{ BarA} / P1)(T1 / 293.15^\circ \text{ K})$$

$$P1 = \text{Operating pressure in BarA}$$

$$T1 = \text{Operating temperature in deg K}$$

### Standard air calibration

- The most common and economical calibration is in air at standard conditions. Data can be presented in actual units of measure or converted to standard units using the operating temperature and pressure.

### Pressurized gas calibration to simulate a constant operating conditions.

- If the operating temperature and pressure are relatively constant and a higher level of accuracy is required, a single pressurized gas calibration can be performed to simulate the operating gas and conditions.

### Application will cover a range of operating temperature and viscosity

- If the gas temperature and pressure is changing by a significant amount and the highest level of accuracy is require, a multiple pressurized gas calibration can be performed.
- A multiple pressure calibration allows the used to perform real time corrections for variations in operating temperature and pressure.
- The SL9200 flow computer offered by FTI can be used to perform these corrections with inputs from temperature and pressure transducers.
- See page 5 for calibration options.



## FT Meter Sizing and End Fittings

Series / Order Code	End Fitting Nominal Inches	ID (mm)	Standard Range (A & H bearing codes)		K Factor	Maximum Frequency Approx.
			Min ALPM	Max ALPM		
FT4-8 <sup>3</sup>	1/2	** 7.6	11.3	85	1589	2000
FT6-8 <sup>4</sup>	1/2	** 9.4	18.4	141.6	848	2000
FT8-8	1/2	** 10	28.3	226.5	565	2000
FT-08	1/2	11	42.5	283	424	2000
FT-10	* 3/4	13	56.6	424	339	2000
FT-12	3/4	14	99.1	708	212	2000
FT-16	1	22	141.6	1699	85	2000
FT-20	1 1/4	25	255	2832	46	1950
FT-24	1 1/2	34	425	4531	21	1500
FT-32	2	44	623	7080	12	1300
FT-40	2 1/2	56	1133	12744	6.3	1200
FT-48 <sup>5</sup>	3	73	1841	21240	3	812
FT-64 <sup>5</sup>	4	98	3540	42480	1	625

**Notes:**

1. Table data based on air @ 14.7 PSIA and 15.6 C.
2. Typical repeatability ±0.1%, typical
3. FT4-8 repeatability ±0.3%, typical
4. FT6-8 repeatability ±0.15%, typical
5. Magnetic pickoff only

\* AE fitting= 5/8"  
 \*\* 11 bore when used with "H" bearing code

Order Code	End Fittings
AE	AN (or MS) external straight threads - 3/8" to 2 1/2" nominal size - 37° flare
NE	NPT external threads - 1/2" to 3" nominal size
HB	Hose Barb - 13 to 51 mm
WF	Wafer type - serrated surface - 13 to 76 mm nominal size
C1	150# Raised Face Flange
C2	300# Raised Face Flange
C3	600# Raised Face Flange
C4	900# Raised Face Flange
C5	1500# Raised Face Flange
C6	2500# Raised Face Flange
D1	DIN Flange PN16
D2	DIN Flange PN40
D3	DIN Flange PN100
D4	DIN Flange PN160
D5	DIN Flange PN250
D6	DIN Flange PN400

### Part Number Structure

<b>F</b>	<b>T</b>	<b>X</b>	<b>X</b>	<b>X</b>	<b>X</b>	<b>X</b>	<b>X</b>	<b>X</b>	<b>X</b>	<b>X</b>	<b>X</b>	<b>X</b>	<b>X</b>	<b>X</b>	<b>X</b>	<b>X</b>	<b>X</b>
Meter Size				End Fittings		Calibration		Tap	Material	Bearing	Pickoff		Optional Designators				



## Calibration

Order Code	# Points	Flow Range	Fluid
NA	10 point	normal 10:1 range	in STD air
TA	20 point	normal 10:1 range	in STD air
BA	10 point, each direction	normal 10:1 range, bi-directional with 1 pick-off	in STD air

Note: "R" and "E" calibrations require user to specify operating gas as well as operation temperature and pressure.

Order Code	# Points	Cal Style	Equivalent Re # Calibration
R1	10 points	Pressurized gas calibration	1 Pressure (specify operating gas, temperature and pressure).
R2	10 points each pressure	Universal Viscosity Curve	2 Pressures (specify operating gas and temperature and pressure range).
R3	10 points each pressure	Universal Viscosity Curve	3 Pressures (specify operating gas and temperature and pressure range).
E1	20 points	Pressurized gas calibration	1 Pressure (specify operating gas, temperature and pressure).
E2	20 points each pressure	Universal Viscosity Curve	2 Pressures (specify operating gas and temperature and pressure range).
E3	20 points each pressure	Universal Viscosity Curve	3 Pressures (specify operating gas and temperature and pressure range).

### 3rd Digit of Calibration

Code	Description
	The third digit of the calibration designator is normally not used and occupied by a dash (-). When required, the following codes are used.
U	To signify required units of measure other than GPM or ACFM
R	To signify special calibration flow range other than normal 10:1
B	To signify both changes in units and special flow range.

### Pressure Tap Designator

Code	Description
G	Standard configuration, meter has no pressure tap.
P	Optional 1/4" male AN pressure tap welded to meter body 180° out of phase to pick-off sensor.

### Material & Bearing Selection

Order Code	Housing	Rotor	Bearing Code
E	316 SST	430F SST	A - D - E - G - H
G	316 SST	316 SST	D - E - G
H	316 SST	17-4 PH SST	A - D - E - G - H

Note: Please contact factory for material code "G".

### Bearing Selection

Order Code	Bearing Description
A	Ball Bearings (standard offering) Materials of construction, 440C SS or equiv. race, balls, and loose crimp cage.
H	Ball Bearing (optional upgrade) Materials of construction, 440C SS race and balls with phenolic resin cage.

### Part Number Structure

F	T	X	X	X	X	X	X	-	X	X	X	X	X	X	X	X
Meter Size				End Fittings		Calibration			Tap	Material	Bearing	Pickoff		Optional Designators		

# FT Series

## Magnetic and RF Pickoff Selection

Order Code	RF (Modulated Carrier)
-1	MS connector
-5	Flying leads/threaded connection
-8	MS connector, 330 $\mu$ H coil
-9	MS connector, 5/8"-18 thread, 1mH coil
-X	I.S. approved, MS connector
SS	I.S. approved, flying leads/smooth body
XX	I.S. approved, flying leads/threaded body
R5	QPS Ex-proof, RTD, flying leads/threaded connector $T_a=70$ C
X5	QPS Ex-proof, flying leads/threaded connector $T_a=70$ C

Order Code	Magnetic
-2	MS connector
-3	Flying leads/threaded connection
-U	I.S. approved, MS connector
PP	I.S. approved, flying leads/smooth body
TT	I.S. approved, flying leads/threaded body
R3	QPS Ex-proof, RTD, flying leads/threaded connector $T_a=70$ C
X3	QPS Ex-proof, flying leads/threaded connector $T_a=70$ C

Notes: 1. Maximum temperature rating of pick-offs are 177° C unless otherwise noted.  
 2. See Amplified Link literature for amplified pick-off codes.  
 3. For QPS approved pickoffs, the max ambient temperature to maintain rating is 70° C.

### Part Number Structure

F	T	X	X	X	X	X	X	X	X	X	X	X	X	X	X	X	X	X
Meter Size				End Fittings		Calibration			Tap	Material	Bearing	Pickoff		Optional Designators				

## Dimensional Drawings

### MS / NPT Fitting

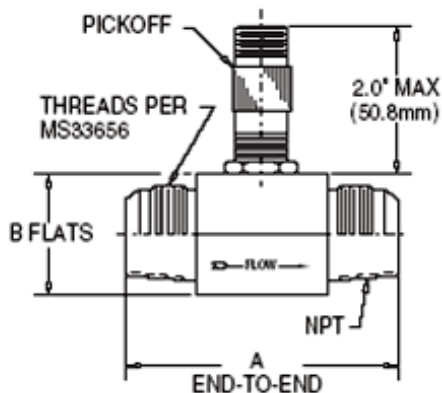

### Flange Fittings

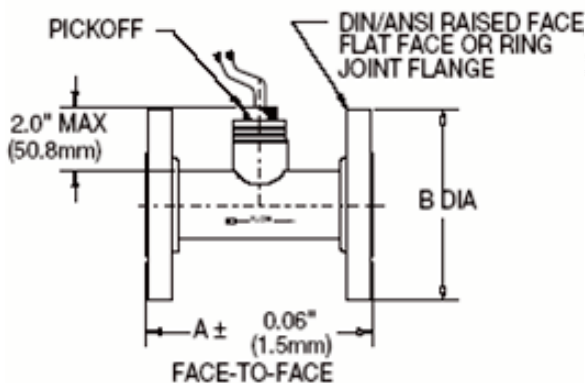

### Hose Barb Fitting

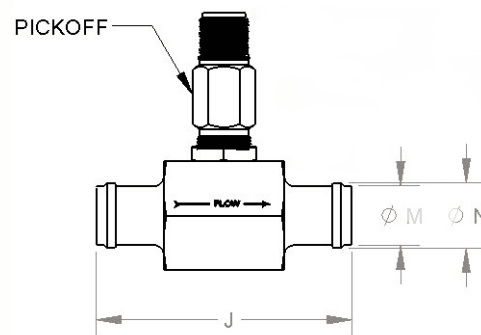

Series	A	B
	mm	mm
FT4-6	62	25
FT-8	62	25
FT-10	69	35
FT-12	83	35
FT-16	90	41
FT-20	103	48
FT-24	117	57
FT-32	154	70
FT-40	226	73
FT-48	330	89
FT-64	N/A	N/A

Series	150#		300#		600#		900#	
	A mm	B mm	A mm	B mm	A mm	B mm	A mm	B mm
FT_8	127	89	127	95	127	95	178	121
FT-10	140	99	140	118	140	118	140	130
FT-12	140	99	140	118	140	118	178	130
FT-16	140	108	140	124	140	124	203	149
FT-20	152	118	152	133	152	133	203	159
FT-24	152	127	152	156	152	156	229	178
FT-32	165	152	165	165	165	165	229	216
FT-40	178	178	178	191	229	191	229	241
FT-48	254	191	254	210	254	210	254	241
FT-64	305	229	305	254	305	273	305	292

Series	J	M	N
	mm	mm	mm
FT4-6	62.2	12.7	14.7
FT-8	62.2	12.7	14.7
FT-10	69.1	16.0	17.8
FT-12	82.6	19.1	21.1
FT-16	90.4	25.4	28.5
FT-20	103.1	31.8	34.8
FT-24	116.6	38.1	41.7
FT-32	153.9	50.8	54.9
FT-40	164.3	63.5	67.8
FT-48	N/A	N/A	N/A
FT-64	N/A	N/A	N/A

Note: 1) Contact factory for DIN dimensions  
 2) DIN flange dimensions per specifications, DIN 2501-1 and DIN EN1092-1



8930 S. Beck Avenue, Suite 107, Tempe, Arizona 85284 USA  
 Tel: (480) 240-3400 • Fax: (480) 240-3401 • Toll Free: 1-800-528-4225  
 E-mail: ftimarket@ftimeters.com • Web: www.ftimeters.com  
 DB 68349 Rev K © 2017 FTI Flow Technology, Inc. Printed in USA