

EL 1100J

Wafer Electromagnetic Flow Meter

Description

The EL 1100J series of wafer electromagnetic sensors represent the state of the art for the accurate flow measurement. This new generation sensor covers the temperature range 32 to 212°F and is available in line sizes from 1.5" through 6".

An electromagnetic flow meter bases its operation on the Faraday Principal, by which a conductor crossing a magnetic field generates a potential. The resultant potential is directly proportional to the flow velocity.

Electronics available for the EL 1100J series consists of the versatile 608 transmitter that can either be AC, DC or battery powered. Electronics can be mounted directly on the flow meter or remotely mounted. The flow meter meets IP 67.

Features

- High accuracy
- No moving parts
- Compact design
- Sealed electrode and coil assembly provides immunity to humidity variation and IP67 protection
- Wide rangeability with a single unit
- No pressure drop
- Bidirectional capability
- 316L electrodes as standard. Because of the third grounding electrode the meter does not require grounding rings if installed in plastic pipes.



**Model EL 1100J
Electromagnetic Wafer Flow
Meter**



Specifications

Accuracy	±0.2% of reading plus zero stability
Zero stability	±0.1% of full scale
Repeatability	±0.1%
Max Fluid Velocity	10 m/s (to maximize performance, size meter to operate as high up in its flow range as possible)
Nominal Line Sizes	1.5", 2", 2.5", 3", 4", 6"
Tube Material	PBT and Fiber Glass; carbon steel coil housing.
Electrode Material	AISI 316L (standard)
Liner Material	PBT & 20% fiber glass
Temperature Range	32 to 212°F
Max Pressure	20bar (305psi)
Max Cable Length	100 meters
Min Conductivity	5 µS/cm, 20 µS/cm for DI water
Rating	IP 67
CE Declaration	CEI EN 61010-1 UNI EN ISO 6817 EN 1434 EN 50081-1 EN 50082-1
Straight Run	5D upstream and 3D downstream minimum
End connections	Wafer

Specifications (cont)

EMC/CE approvals	EN 61326:1997 EN 61326/A3:2003 EN 55022/A2:2003 EN 61000-4
Compatible electronics	MC608 series MC106 series
Weight (max)	See table

Weight

Size	Nominal Diameter	Weight
1.5"	DN 40	1.5 Kg (3.30lb)
2"	DN 50	1.8 Kg (3.97lb)
2.5"	DN 65	2.5 Kg (5.41lb)
3"	DN 80	3.0 Kg (6.61lb)
4"	DN100	4.0 Kg (8.81lb)
6"	DN 150	6.5 Kg (14.33lb)

Maximum Cable Length VS Conductivity

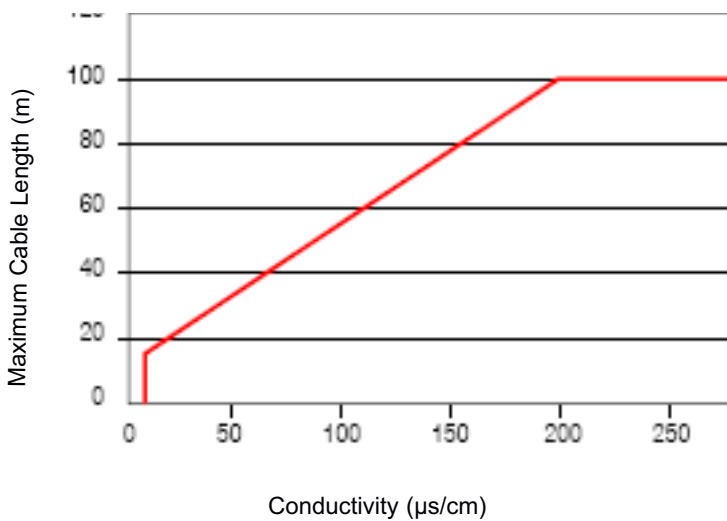

EL 1100J Flow Range

Size	Nominal Diameter	Minimum Flow*	Maximum Flow
1.5"	DN 40	9.5 GPM	189.3 GPM
2"	DN 50	13.2 GPM	263.4 GPM
2.5"	DN 65	25.5 GPM	509.9 GPM
3"	DN 80	39.8 GPM	796.7 GPM
4"	DN100	64.8 GPM	1295 GPM
6"	DN 150	140 GPM	2800 GPM

* Minimum flow rate is defined as the flow rate at 0.5 m/s and maximum flow is defined at 10 m/s.



MC 608A/B Series Features

- High end controller
- Bi directional functionality
- AC and DC versions
- Battery powered version (6 to 10 Year life)
- Internal Data logging
- Low power consumption mode
- Large graphics display
- Digital outputs
- Analog outputs
- Alarm outputs
- Windows based programming tool

Overall Dimensions

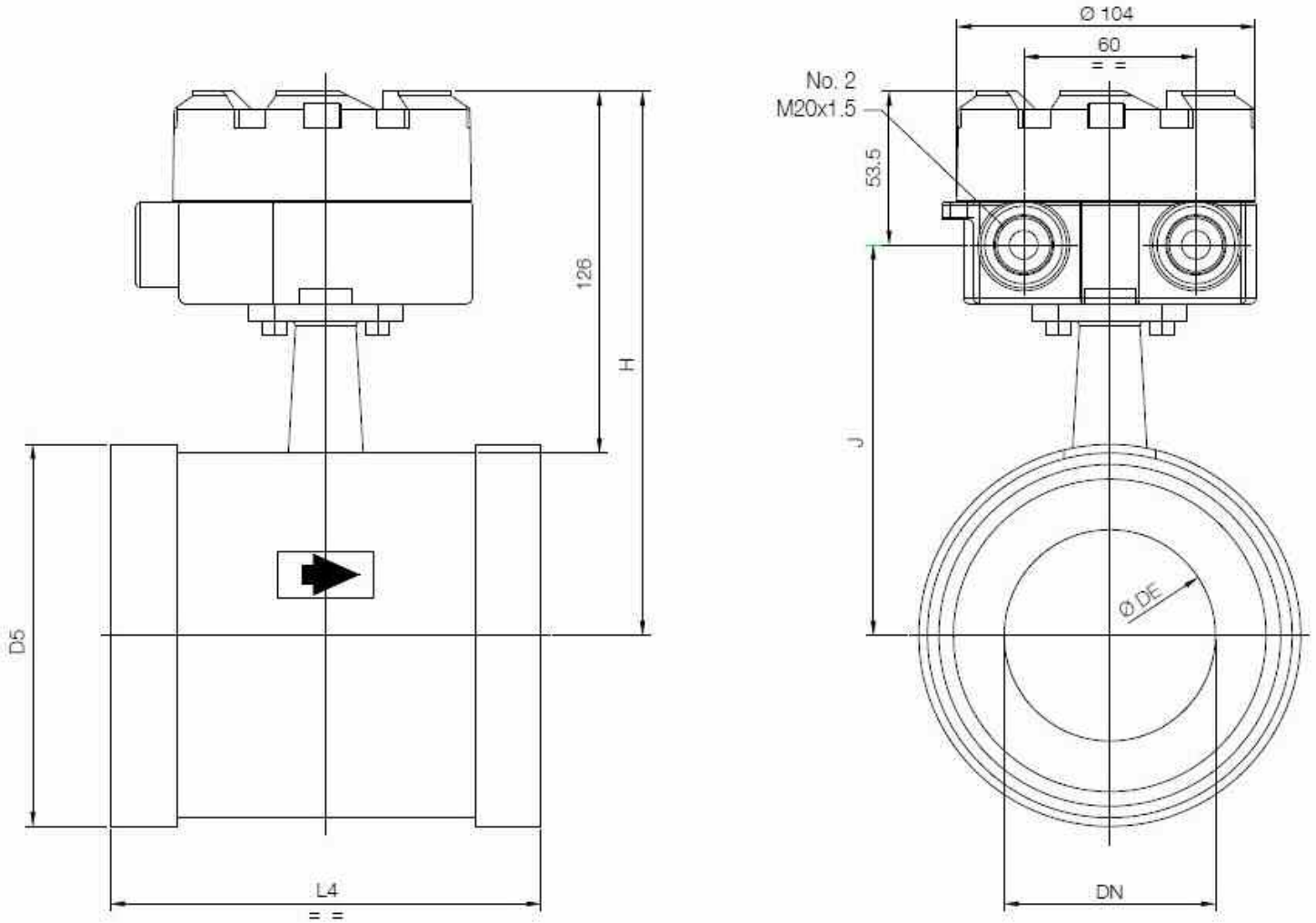

Size	DN (mm)	D5	L4	J	H
1.5"	40	86	96	115	168
2"	50	103	86	122	175
2.5"	65	122	104	133	186
3"	80	134	112	138	192
4"	100	160	130	148	202
6"	150	220	196	180	234

EL 1100J & 608 Transmitter

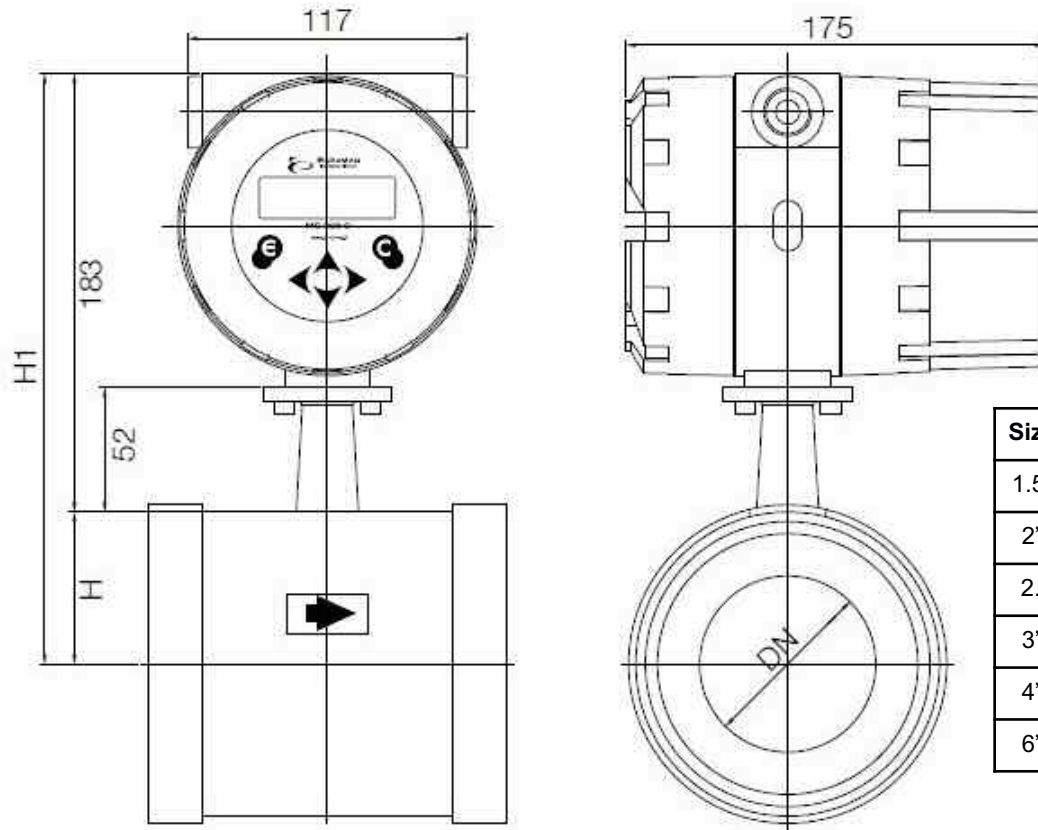

Size	DN (mm)	H(mm)	H1(mm)
1.5"	40	42	225
2"	50	49	232
2.5"	65	60	243
3"	80	65.5	248.5
4"	100	75.5	258.5
6"	150	108	291

EL 1100J System Model Number

01-		-	A	A	A	-			A
-----	--	---	---	---	---	---	--	--	---

Size	DN	Code
1.5"	DN40	100575
2"	DN50	100576
2.5"	DN65	100577
3"	DN80	100578
4"	DN100	100579
6"	DN150	100580

Transmitter & Power	Code
608A 90 to 264AC Transmitter	A
608A 24V Transmitter	B
608B Battery Powered	L

Integral or Remote	Code
Integral	A
Remote, 5m	B
Remote, 10m	D
Remote, 15m	E
Remote, 20m	F
Remote, 30m	G
Remote, 40m	H
Remote, 50m	J
Remote, 75m	K



8930 S. Beck Avenue, Suite 107, Tempe, Arizona 85284 USA
 Tel: (480) 240-3400 • Fax: (480) 240-3401 • Toll Free: 1-800-528-4225
 E-mail: ftimarket@ftimeters.com • Web: www.ftimeters.com
 DB 100808 D © 2021 FTI Flow Technology, Inc. Printed in USA



Trademarks are the property of their respective companies.
 Specifications are for reference only and are subject to change without notice.