

# EL 1000

## Wafer Electromagnetic Flow Meter

### Description

The EL 1000 series of electromagnetic sensors represent the state of the art for the accurate measurement for water cycle and process applications. Flow meters are available in line sizes from 1" through 12". This new generation sensor incorporates improvements to the signal protection as well as the magnetic distribution elements to create a unique electromagnetic field profile that ensures accuracy not only in turbulent flow, but also during the transitional and laminar flow regimes.

An electromagnetic flow meter bases its operation on the Faraday Principal, by which a conductor crossing a magnetic field generates a potential. The resultant potential is directly proportional to the flow velocity. The EL 1000 series flow meters utilize 304 stainless steel flow tube, four Hastelloy C electrodes are standard for 2" and above, with one electrode being used for ground to eliminate the need for costly grounding rings required by other manufactures. The standard liner materials are Ebonite or PTFE, with PTFE available as an option on 5" and larger meters. The sensor exterior surface is coated with acrylic paint, providing excellent resistance to water.

Electronics available for the EL 1000 series consists of the versatile 608 transmitter that can either be AC, DC or battery powered. Electronics can be mounted directly on the flow meter or remotely mounted. When the electronics are remotely mounted the entire flow meter meets IP68 suitable for permanent immersion in water up to a depth of 10 meters.

### Features

- No moving parts
- Hastelloy C electrodes standard
- Grounding electrode eliminates ground rings
- Sealed electrode and coil assembly provides immunity to humidity variation and IP67 protection
- Wide rangeability with a single unit
- No pressure drop
- Bidirectional capability
- Remote & integral versions available
- AC/DC & battery powered



**Model EL 1000  
Electromagnetic Flow Meter**

### Specifications

Accuracy	±0.5% of reading plus zero stability
Zero Stability	±0.1% of full scale
Repeatability	±0.2%
Max Fluid Velocity	10 m/s
Tube Material	304 stainless steel
Line Sizes	1" to 12"
Electrode Material	Hastelloy C (standard)
Liner Material	Ebonite or PTFE 1.5" and below: PTFE only 2" to 4": PTFE standard 5" and above: Ebonite standard
Max Temp Range	-40° to 176° F
Max Pressure	Dependent on flange rating
Coupling Flange	ANSI 150, ANSI 300
Max Cable Length	75 meters
Min Conductivity	5 µS/cm, 20 µS/cm for DI water
Rating	IP68 to 1.5 meters with remote transmitter
CE Declaration	EN 61326:1997 to EN 61326/A3:2003
Straight Run	5D upstream and 3D downstream minimum

## EL 1000 System Model Number

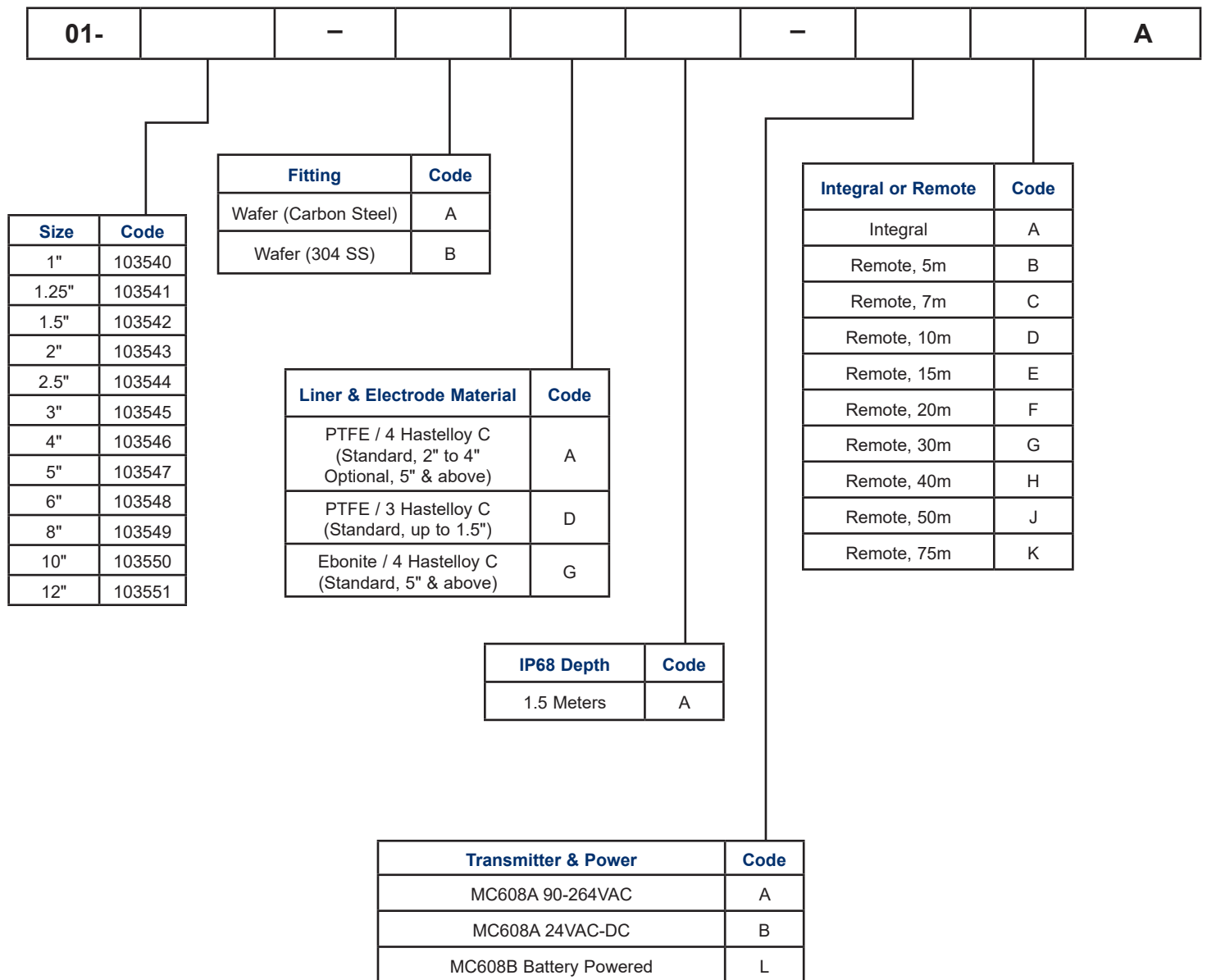

## EL 1000 with MC608A mounted

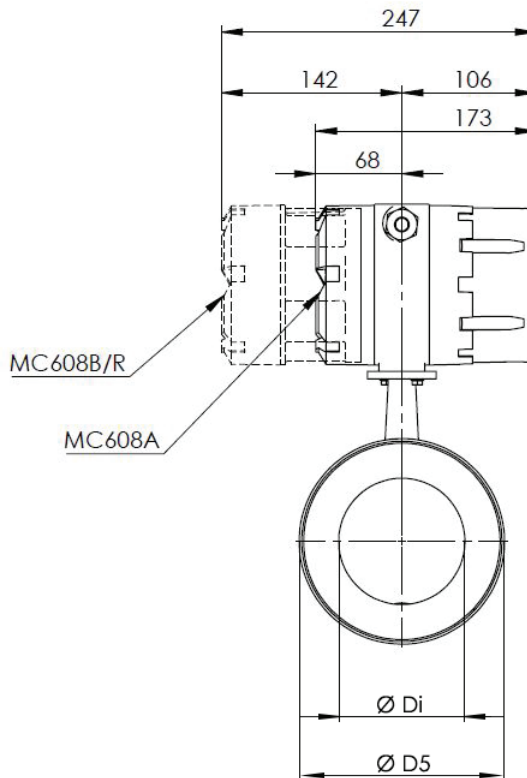
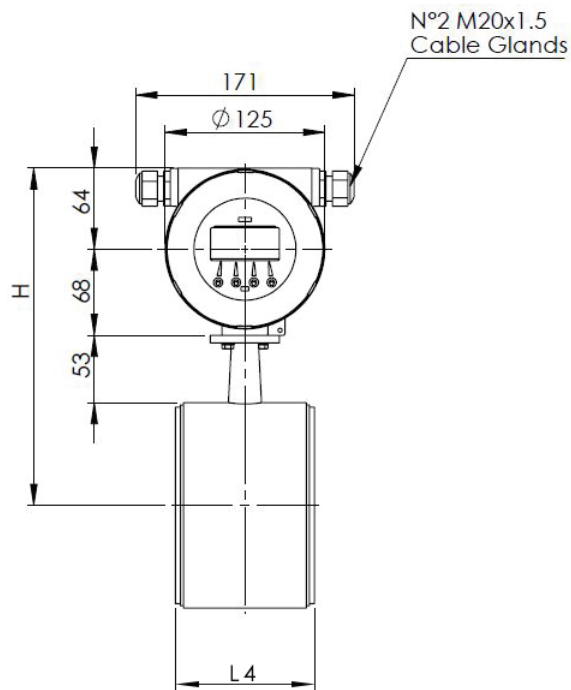

### EL 1000 Electronics

The EL 1000 interfaces to an integral or remote mounted MC608 transmitter with backlit display. The system can be powered with 110/240AC, 24V DC or battery powered.



### MC 608A/B Series Features

- High end controller
- Bidirectional functionality
- AC and DC versions
- Battery powered version (6 to 10 Year life)
- Internal Data logging
- Low power consumption mode
- Large graphics display
- Digital outputs
- Analog outputs
- Alarm outputs
- Windows®-based programming tool

Size (Inches)	L4	Di	D5	H
1.00	3.54	0.94	2.91	8.19
1.25	3.54	1.26	3.27	8.39
1.50	3.54	1.38	3.46	8.46
2.00	3.54	1.85	4.02	8.74
2.50	3.94	2.48	4.49	8.98
3.00	3.54	2.95	5.00	9.25
4.00	4.33	3.89	6.34	9.92
5.00	4.33	4.88	7.32	10.39
6.00	5.12	5.98	8.50	10.98
8.00	6.69	7.91	10.51	12.00
10.00	6.69	10.04	12.56	13.03
12.00	7.87	12.13	14.60	14.06



Trademarks are the property of their respective companies.  
Specifications are for reference only and are subject to change without notice.

8930 S. Beck Avenue, Suite 107, Tempe, Arizona 85284 USA  
Tel: (480) 240-3400 • Fax: (480) 240-3401 • Toll Free: 1-800-528-4225  
E-mail: [ftimarket@ftimeters.com](mailto:ftimarket@ftimeters.com) • Web: [www.ftimeters.com](http://www.ftimeters.com)

