

Autobell® Bell Prover

Primary Standard Gas Calibration System

Description

The New Generation Autobell®, a primary standard gas calibration system, is used to accurately measure a displaced volume of gas at a constant pressure. Interface electronics are provided to measure displaced volume and the time over which the volume is displaced so that a precise flow rate can be determined. To calibrate a gas flow meter using the Autobell®, the flow meter must be installed upstream of the bell so that all gas flowing through it is captured by the calibrator.

The Autobell® system consists of a vertical inner tank surrounded by an outer shell. The annular space between the inner tank and outer shell is filled with sealing liquid (water or oil). An inverted tank, called the bell, is placed over the inner tank with the wall of the bell riding in the annular space filled with sealing liquid. The liquid provides a bubble-tight, frictionless seal which allows for smooth linear movement of the bell at essentially zero pressure drop.

The bell is precision-balanced so that pressure remains constant throughout the stroke. A large counterweight is used to balance the weight of the bell while a small counterweight hanging from an involute cam is used to compensate for buoyancy and other linear effects experienced by the bell as it moves along its stroke.

The Autobell® has a unique feature not found on other bell prover systems — a large counterweight is suspended in a small tank which is hydraulically connected to the annular space in which the bell rides. The counterweight is machined so that its cross-sectional area exactly matches the cross-sectional area of the bell. As the bell moves out of the sealing liquid, the counterweight moves into the liquid so that the level of the sealing liquid remains constant. This allows for a more accurate/repeatable calibration since the varying liquid level is no longer an influence.

The bell is a precision cylinder so that linear movement of the bell is proportional to displaced volume. A rotary encoder is directly coupled to the pulley shaft and produces pulses proportional to the linear displacement of the bell. Interface electronics provide a means of counting the encoder pulses. Through hardware gating, the encoder pulses are synchronized with a precision timer. An exact number of pulses and corresponding time are accumulated over a calibration run.



Autobell® Bell Prover

Primary Standard Bell Prover Gas Calibration System

Features

- Calibrates all principle types of flow meters — turbine, variable area and thermal
- $\pm 0.2\%$ uncertainty of volumetric flow rate measurement (95% C.L.) typical
- Automatic data acquisition through PC and interface
- Displays, prints and analyzes data in desired units of measure
- Automatic level compensation for liquid seal volume
- Stainless steel construction
- Directly traceable to the National Institute of Standards and Technology (NIST)
- Simplified system calibration

Autobell® Bell Prover

Specifications

Operating Pressure	0.2" H ₂ O Max. (standard)
Pressure Drop	0.2" H ₂ O Max. (standard)
Operating Temperature	65° F to 75° F (18° C to 24° C)

Electronic Description

The Autobell Bell Prover comes complete with the required interface electronics and an industrial PC computer. These electronics are interfaced to the rotary encoder, temperature/pressure transmitters, and a solenoid valve to provide automatic data acquisition with low-level control over the system.

Calware™, Flow Technology's flow calibration program for Windows® 11, provides an intuitive user interface which conveniently presents all calibrator controls and parameter settings on a single active screen and simplifies parameter selection.

Calware™ is menu-driven and has been designed to provide a user-friendly environment for people who are not experienced with computers. The system is partitioned by functionality, allowing for visual and turbine meter calibrations, storage and retrieval of calibration data, tabular data reporting, and editing of calibration data reports.

The Autobell Bell Prover system has been designed to automatically acquire and display data. After the user sets the desired flowrate and commands the data to be taken, the computer will automatically record and display both the raw and calculated data.

Once the entire calibration is complete, the software offers the ability to save, edit, sort or print the data in tabular or graphical form. This process is repeated until the total number of desired data points have been recorded.

Specifications are for reference only and are subject to change without notice.

Model Numbering System

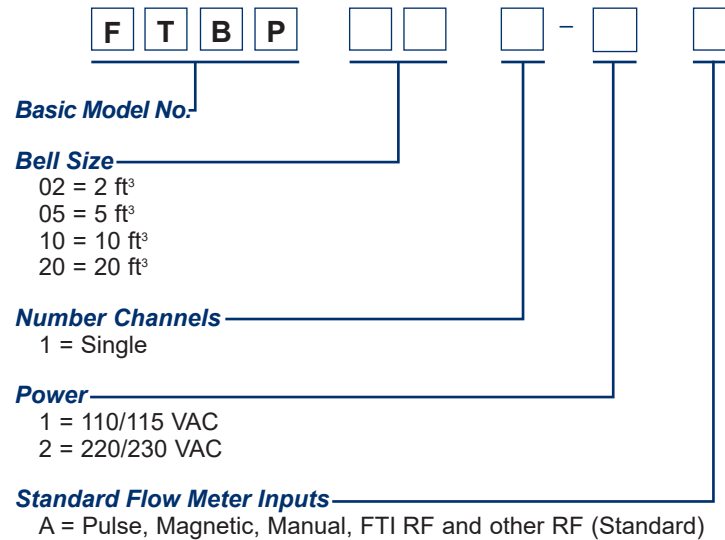

- Bell Size**
- 02 = 2 ft³
 - 05 = 5 ft³
 - 10 = 10 ft³
 - 20 = 20 ft³

- Number Channels**
- 1 = Single

- Power**
- 1 = 110/115 VAC
 - 2 = 220/230 VAC

Standard Flow Meter Inputs	Accuracy
Frequency 0.5Hz-10K Hz	±0.005% of Reading
(0 - 10V P-P)	
Signal Conditioner 0.5Hz-4K Hz	±0.2 Hz @4K

Optional Flow Meter Inputs

- Analog Voltage 0-5 VDC
- Analog Voltage 0-10 VDC
- Analog Current 4-20 mA
- Analog Current 10-50 mA

Stroke Time at Maximum Flow

- FTBP-02 = 12 seconds
- FTBP-05 = 12 seconds
- FTBP-10 = 12 seconds
- FTBP-20 = 9.6 seconds

Model Part Numbering System

Bell Type	Flow Range ACFM (ALPM)	Dimensions (L x W x H) Inches (m)	Weight Pounds (kg)	Displacement Volume Cubic Feet (L)
FTBP-02	0.1 to 10 (2.83 to 283)	27" x 34" x 64" (0.69 x 0.86 x 1.6)	200 dry (91)	2 (57)
FTBP-05	0.25 to 25 (7.08 to 708)	30" x 46" x 99" (0.76 x 1.2 x 2.5)	300 dry (136)	5 (142)
FTBP-10	0.5 to 50 (14.2 to 1,416)	41" x 54" x 125" (1.0 x 1.4 x 3.2)	600 dry (272)	10 (283)
FTBP-20	1.25 to 125 (35.4 to 3,540)	47" x 66" x 137" (1.2 x 1.7 x 3.5)	1,000 dry (454)	20 (566)



8930 S. Beck Avenue, Ste 107, Tempe, Arizona 85040 USA
 Tel: (480) 240-3400 • Fax: (480) 240-3401 • Toll Free: 1-800-528-4225
 E-mail: ftimarket@ftimeters.com • Web: www.ftimeters.com
 DB 62066 Rev F © 2026 FTI Flow Technology, LLC.

